



Range of heights – 22u through to 47u

Range of depths – 600, 800, 1000mm

Aesthetically pleasing

Load carrying capacity 400kg

Features

- Available in 5 heights, 22u, 27u, 39u, 42u, 47u
- Choice of depths in most sizes, 600mm, 800mm, 1000mm
- Enhanced vertical patch cable management system
- Aesthetically pleasing framed safety glass front door
- Quick release doors and side panel
- Swing lock handle on front door
- 1u height marking on 19" mounting profiles
- Adjustable front and rear 19" mounting profiles
- Horizontal strength supporting bars (a cable tray can be fixed to these)
- Open base for maximum cable access
- Load carrying capacity 400KG
- Available assembled or flat pack

Product Overview

The Excel 800 series is a range of 19" free standing cabinets designed for installation of both cabling and networking equipment. They are ideal for use across a range of applications including local area networking (LAN) cabling and hardware, plus the housing of security and AV equipment.

Each cabinet is designed with strength, ease of use and aesthetics in mind. Features such as incremental 1U marking on the mounting profiles, quick release doors and side panels, fully horizontally adjustable front and rear profiles and full access through the base of the cabinet make the product extremely flexible.

Vertical cable management provides full height channels adjacent to the front mounting profiles. Patch cables can be routed from the channel into patch panels or equipment through the frequently positioned access slots. To complete the aesthetically pleasing look, the channel – and all installed patch cables are covered with a hinged door plate, which is quickly and easily released via a slam latch lock.

The aesthetically pleasing design is completed with the use of a framed smoked safety glass front door fitted with a swing handle lock. Door hinging can be quickly and easily reversed left to right. The 800 series is available in 5 heights from 22u through to 47u. In certain sizes a choice of 600, 800 and 1000mm depth options are available. Each cabinet is supplied as standard with lockable glass front door, metal rear door and lift off metal side panels. Two sets of steel adjustable 19" mounting profiles are fitted, and the roof can be fitted with fan trays and cable entry brush strips. To minimize the weight and size of the removable side panel the 800 and 1000mm deep cabinets are designed with a two piece side panel. The removable side panel is 595mm deep.

A full range of Excel accessories are available to complete cable or equipment installation from cable tray, plinth kits and shelving through to ventilation and power distribution units.

Exploded Views

600mm deep

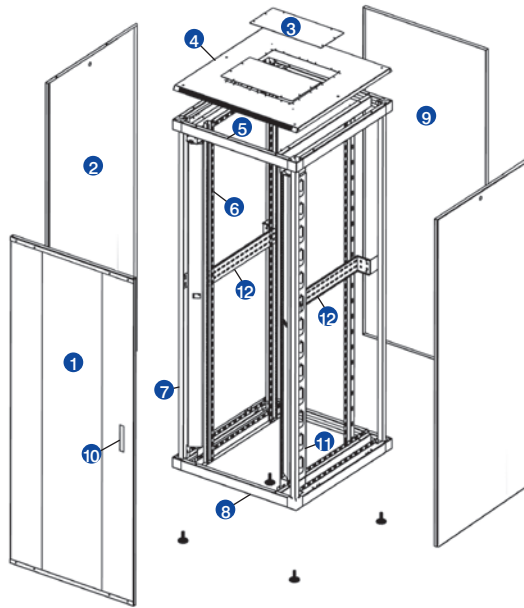

800mm & 1000mm deep

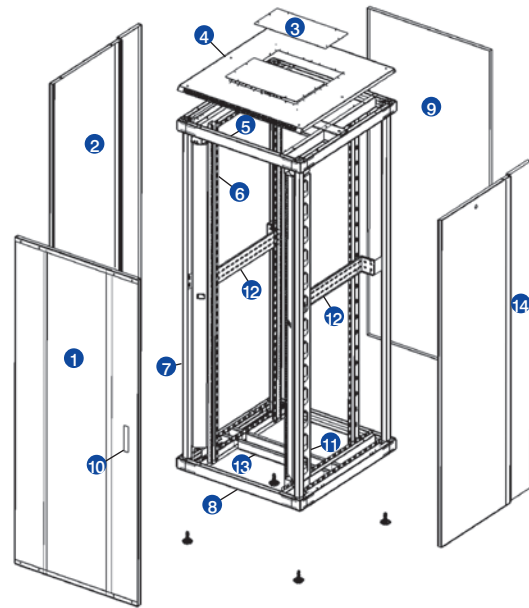

Sectional Views

Side View

600mm deep

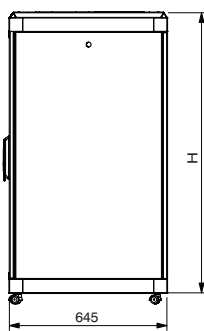

800mm deep

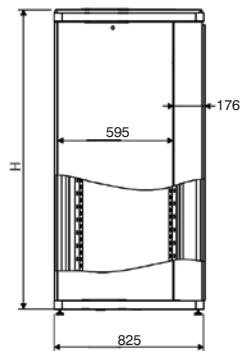

1000mm deep

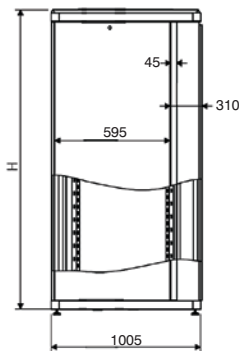

- ① Front door
- ② Side panel
- ③ Roof panel, removeable entry plates
- ④ Roof panel
- ⑤ Upper frame
- ⑥ Mounting profile
- ⑦ Corner post
- ⑧ Lower frame
- ⑨ Rear door
- ⑩ Swing lock handle
- ⑪ Full height vertical management
- ⑫ Horizontal strength supporting bars
- ⑬ Strength cross member (1000mm deep only)
- ⑭ Side infill panel

All dimensions are shown in mm

Front View

600mm, 800mm & 1000mm deep

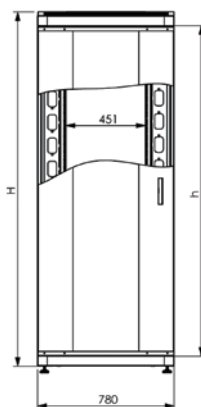

Rear View

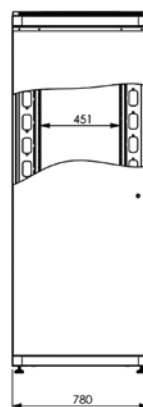

Plan View

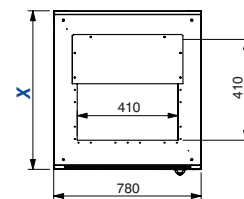

600mm deep X = 645mm

800mm deep X = 825mm

1000mm deep X = 1005mm

Product Specification

Material Thickness

Cabinet Part	
Upper and lower case	1.50mm
Top cover and fan entry plate	1.20mm
19" mounting angles	2.00mm
Vertical cable management	1.50mm
Rear door and side panels	1.20mm
Side extension panel*	1.00mm
Front door frame	1.50mm
Front door glass	4.00mm

* 800mm & 1000mm deep versions only

Product Standard Compliance

Manufacturing facility	ISO 9001:2000
19" mounting angles	IEC297-1
Overall cabinet dimensions	IEC297-2
Load carrying capacity	400kg
Paint finish, grey cabinet	Ral 7035
Paint finish, front door blue trim	Ral 5013
Glass door, safety specification	BS3193:1993
Surface treatment	Fosfat Coating

Product Features



- Angled vented roof



- Lockable lift off side panels



- Adjustable 19" mounting profiles



- Open base for maximum cable access



- Swing handle lock



- Enhanced vertical patch cable management system



- Clearly identified u height

Part Number Information

U Size	Width (mm)	Overall Height (mm)	Depth (mm)	Part Number - Assembled	Part Number - Flat Pack
800 Series					
22u	800	1149	600	540-247	540-247-FP
22u	800	1149	800	540-249	540-249-FP
27u	800	1326	600	540-250	540-250-FP
27u	800	1326	800	540-255	540-255-FP
27u	800	1326	1000	540-256	540-256-FP
39u	800	1904	600	540-260	540-260-FP
39u	800	1904	800	540-270	540-270-FP
39u	800	1904	1000	540-272	540-272-FP
42u	800	2038	600	540-275	540-275-FP
42u	800	2038	800	540-280*	540-280-FP*
42u	800	2038	1000	540-281	540-281-FP
47u	800	2260	600	540-285	540-285-FP
47u	800	2260	800	540-290	540-290-FP
47u	800	2260	1000	540-282	540-282-FP

***Also available in black from stock: Part Numbers 540-280-BK and 540-280-BK-FP**

Note: For overall height when using jacking feet please add 30mm
 For overall height when using castors please add 75mm
 For overall height when using plinth please add 100mm approximately

The Excel range of floor standing cabinets is also available in 800mm wide options. We also supply a broad range of wall mounted cabinets.



Virtware - Sol. Int. Telecomunicações, Lda
 Rua dos Canasteiros, 394
 4400-404 Canidelo VNG, Portugal

Tel: +351 918205881
 Email: info@virtware.pt Web: www.virtware.pt